

AVERY DENNISON MARKETING SPECIFICATION

TOLERANCES: IN. = ± .030 in
MM = ± 0.7 mm

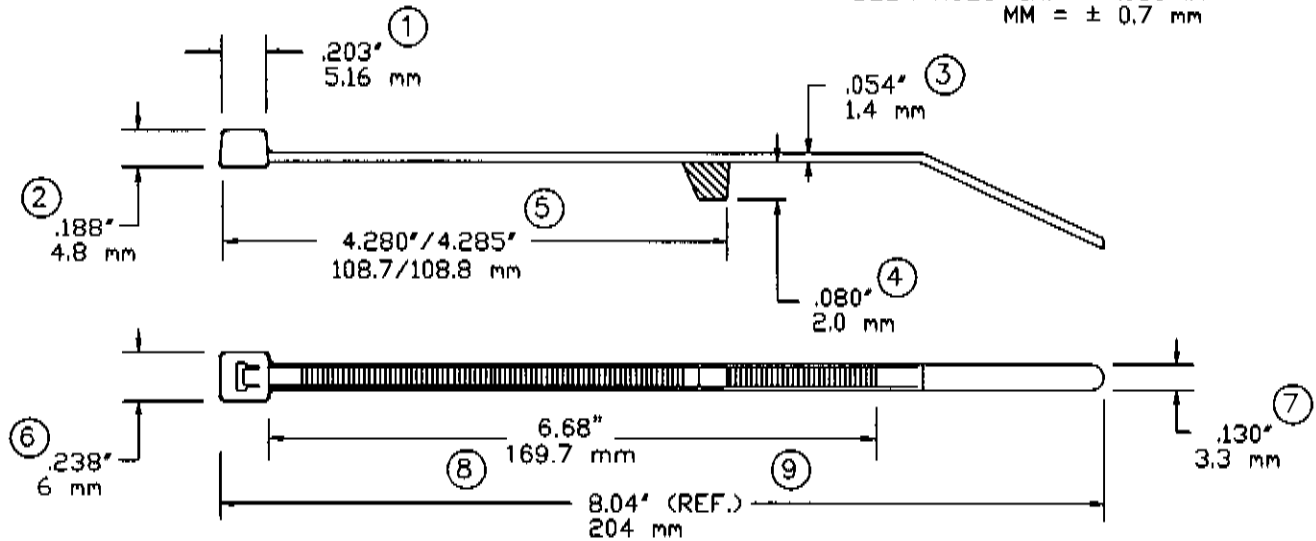

NOT TO SCALE

TENSILE STRENGTH:	40 lbs. / 18.1 kg. MINIMUM PER MIL-S-23190.
MATERIAL:	NYLON 6/6 PER ASTM D4066 BLACK HEAT STABILIZED
WEIGHT:	.02890 oz. / .85 grams
MAXIMUM BUNDLE DIAMETER:	2-1/8"
APPLICATION TOOL:	TOOL, HAND ADJUSTABLE, FOR PLASTIC TIE DOWN STRAP, AVERY DENNISON PART NUMBER 12001.
TOOL TENSION SETTING:	3-5
PACKAGED IN:	1000 PACKS IN SEALED BAGS



AVERY DENNISON

FASTENER DIVISION
FITCHBURG, MA 01420 U.S.A.
TEL. 1-800-225-5913
MA. 978-353-8157

DESCRIPTION:

8" STOPPER TIE

APPROVAL:

J. Boyle 5-1-06

STOCK NO.

10406

REV

E