

AVERY DENNISON MARKETING SPECIFICATION

TOLERANCES: IN. = ± .030 in
MM = ± 0.7 mm

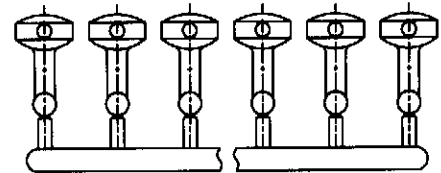
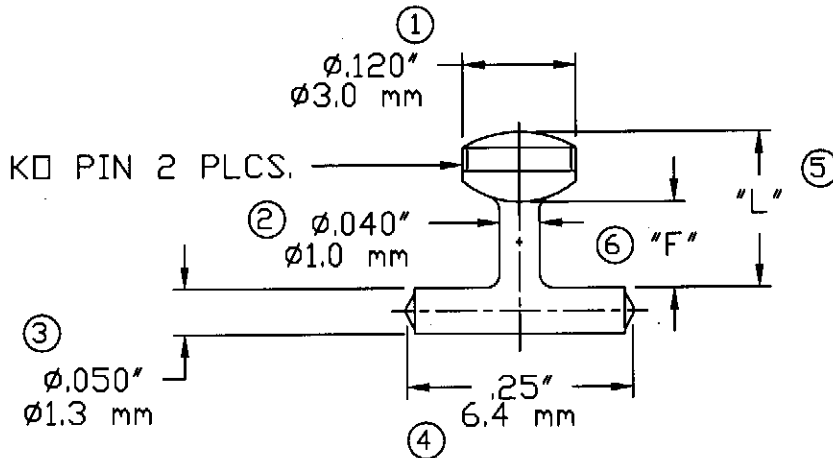

NOT TO SCALE

TENSILE STRENGTH:	4 lbs. MIN. (1.8 kg.)
MATERIAL:	POLYURETHANE
CLIP QUANTITY:	48 FASTENERS
APPLICATION TOOL:	MARK II - COMMERCIAL BUTTONEER® ATTACHING TOOL #06110
PACKAGED :	5000 FASTENERS PER BOX MINIMUM

STK.NO	DESCRIPTION	WEIGHT	"F"	"L"
06092-1	NATURAL - SHORT	.024 GRAMS	.10" / 2.5 mm	.165" / 4.2 mm
06091-1	BLACK - SHORT	.024 GRAMS	.10" / 2.5 mm	.165" / 4.2mm
06101-1	NATURAL - LONG	.027 GRAMS	.21" / 5.3 mm	.280" / 7.1 mm
06102-1	BLACK LONG	.027 GRAMS	.21" / 5.3 mm	.280" / 7.1 mm



FASTENER DIVISION
FITCHBURG, MA 01420 U.S.A.
TEL. 1-800-225-5813
MA. 978-353-8157

DESCRIPTION:

BUTTONEER® STANDARD

APPROVAL:

[Signature] 13 MAY 2009

STOCK NO.

SEE TABLE

REV

B